

M92 Q MULTICUT 4

*The perfect grooving and cutting system
for many applications*

- ▶ *Parting off and grooving*
- ▶ *Threading*
- ▶ *Precision grooving*
- ▶ *Full radius grooving*
- ▶ *Special profiles*



↑
Perfect
assembly



M92 Q MULTICUT 4

The perfect Grooving and Cutting System for many applications

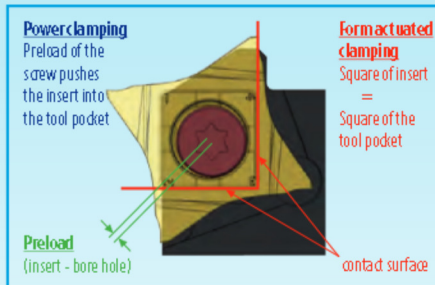

Vertical positioned inserts are well known. However, the segmented MULTICUT 4 inserts represent the new state of art technology. This improved development features a lot of advantages:



Perfect power and form actuated clamping.

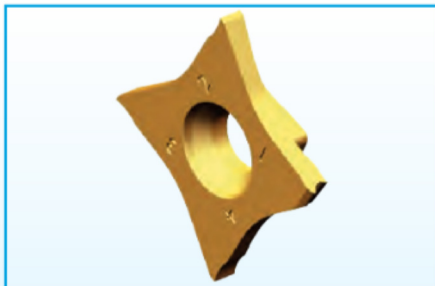

Reinforced solidity of insert suppresses vibrations. Achieves high and constant tool life. Maintains reliability on cutting operations.



Reinforced area of the cutting edge grants stability.

In case a cutting edge is damaged all other edges can be used independently.



Precise re-positioning when changing cutting edges.

Fast and safe fixing in pocket.

Only 1 insert pocket for many inserts for different cutting operations.

New cutting geometry!

MULTICUT 4 - Insert Designation Code

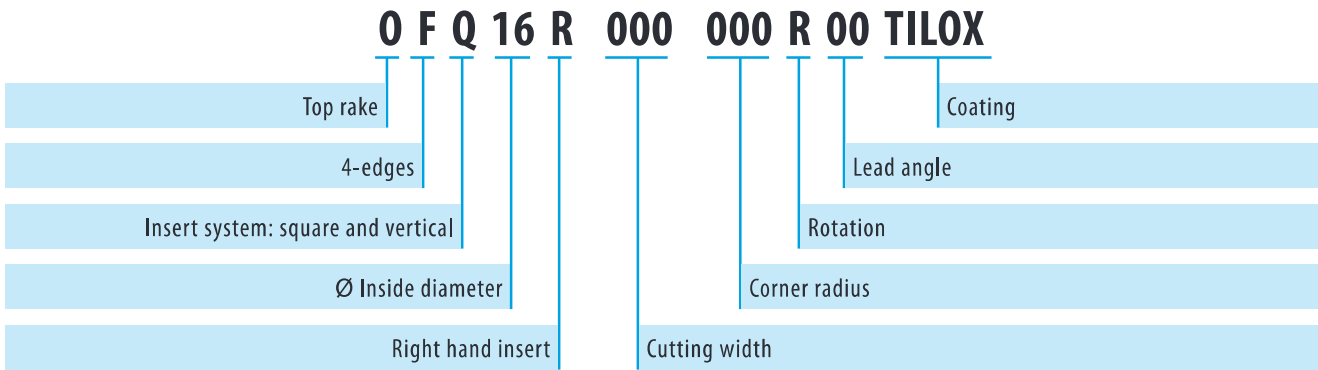

MULTICUT 4 Sharp teeth - sharp edges



MULTICUT 4 -Cutting insert with 4 edges for grooving and parting off

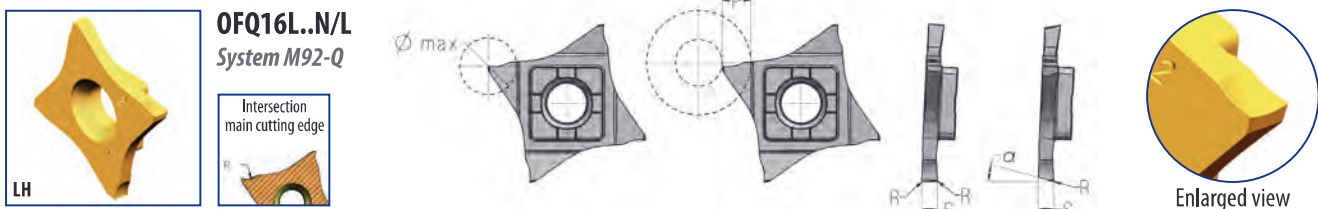

WG400 Ref.	FM NANOSPEED ID-Nr.	FM TILOX ID-Nr.	KM CARBOSPEED ID-Nr.	⌀	P	R	s ±0.05	α°	Ømax.
OFQ16L 050 000 N 00	31019	31020	43890	N	2,5	0,00	0,50	0	5,0
OFQ16L 100 000 N 00	31021	31022	43891	N	3,5	0,00	1,00	0	7,0
OFQ16L 120 000 N 00	35046	38719	43892	N	6,5	0,00	1,20	0	13,0
OFQ16L 150 010 N 00	31239	31238	43893	N	6,5	0,10	1,50	0	13,0
OFQ16L 200 010 N 00	31026	31027	43894	N	6,5	0,10	2,00	0	13,0
OFQ16L 200 020 N 00	43669	43670	44154	N	6,5	0,20	2,00	0	13,0
OFQ16L 250 010 N 00	30946	31028	43895	N	6,5	0,10	2,50	0	13,0
OFQ16L 250 020 N 00	43671	43672	44155	N	6,5	0,20	2,50	0	13,0
OFQ16L 300 010 N 00	31029	31030	43896	N	6,5	0,10	3,00	0	13,0
OFQ16L 300 020 N 00	43673	43674	44156	N	6,5	0,20	3,00	0	13,0
OFQ16L 100 000 L 06	31031	31032	43897	L	3,5	0,00	1,00	6	7,0
OFQ16L 100 000 L 15	31033	31034	43898	L	3,5	0,00	1,00	15	7,0
OFQ16L 120 000 L 06	38720	38721	43899	L	6,5	0,00	1,20	6	13,0
OFQ16L 150 010 L 06	37813	26738	43900	L	6,5	0,10	1,50	6	13,0
OFQ16L 150 010 L 15	31266	31265	43901	L	6,5	0,10	1,50	15	13,0
OFQ16L 200 010 L 06	31039	31040	43902	L	6,5	0,10	2,00	6	13,0
OFQ16L 200 020 L 06	43675	43676	44157	L	6,5	0,20	2,00	6	13,0
OFQ16L 200 010 L 15	31041	31042	43903	L	6,5	0,10	2,00	15	13,0
OFQ16L 200 020 L 15	43677	43678	44158	L	6,5	0,20	2,00	15	13,0

Comment:

Segmented and ground micrograin insert.
Positive top-rake with **chipforming** groove, beginning with 1,5 mm width to 3 mm. * LH = Left Hand = for clockwise (cw) rotation

Fitting tool holders and blades



[Technical section page 205 onwards](#)

MULTICUT 4 - Cutting insert with 4 edges for grooving and parting off



OFQ16R...N/R
System M92-Q

Intersection
main cutting edge

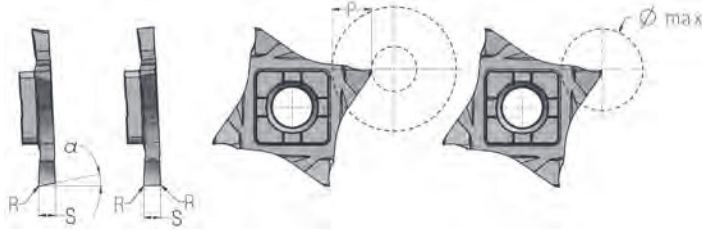

Enlarged view

WG 400 Ref.	FM NANOSPEED	FM TILOX	KM CARBOSPEED	()	P	R	$s_{\pm 0,05}$	α°	$\varnothing_{max.}$
	ID-Nr.	ID-Nr.	ID-Nr.						
OFQ16R 050 000 N 00	30971	30972	43904	N	2,5	0,00	0,50	0	5,0
OFQ16R 100 000 N 00	30973	30974	43905	N	3,5	0,00	1,00	0	7,0
OFQ16R 120 000 N 00	35044	38722	43906	N	6,5	0,00	1,20	0	13,0
OFQ16R 150 010 N 00	31257	31237	43907	N	6,5	0,10	1,50	0	13,0
OFQ16R 200 010 N 00	30977	30978	43908	N	6,5	0,10	2,00	0	13,0
OFQ16R 200 020 N 00	43679	43680	44159	N	6,5	0,20	2,00	0	13,0
OFQ16R 250 010 N 00	30945	30979	43909	N	6,5	0,10	2,50	0	13,0
OFQ16R 250 020 N 00	43681	43682	44160	N	6,5	0,20	2,50	0	13,0
OFQ16R 300 010 N 00	30980	30981	43910	N	6,5	0,10	3,00	0	13,0
OFQ16R 300 020 N 00	43683	43684	44161	N	6,5	0,20	3,00	0	13,0
OFQ16R 100 000 R 06	30982	30983	43911	R	3,5	0,00	1,00	6	7,0
OFQ16R 100 000 R 15	30984	30985	43912	R	3,5	0,00	1,00	15	7,0
OFQ16R 120 000 R 06	38723	38724	43913	R	6,5	0,00	1,20	6	13,0
OFQ16R 150 010 R 06	31262	31261	43914	R	6,5	0,10	1,50	6	13,0
OFQ16R 150 010 R 15	31264	31263	43915	R	6,5	0,10	1,50	15	13,0
OFQ16R 200 010 R 06	30990	30991	43916	R	6,5	0,10	2,00	6	13,0
OFQ16R 200 020 R 06	43685	43686	44162	R	6,5	0,20	2,00	6	13,0
OFQ16R 200 010 R 15	30992	30993	43917	R	6,5	0,10	2,00	15	13,0
OFQ16R 200 020 R 15	43687	43688	44163	R	6,5	0,20	2,00	15	13,0

Comment:

Segmented and ground micro-grain insert.
Positive top-rake with **chipforming** groove, beginning with
1,5 mm width to 3 mm.

* RH = Right Hand = for counter clockwise (ccw) rotation

Fitting tool holders and blades



p. 35



p. 36



p. 36



p. 159

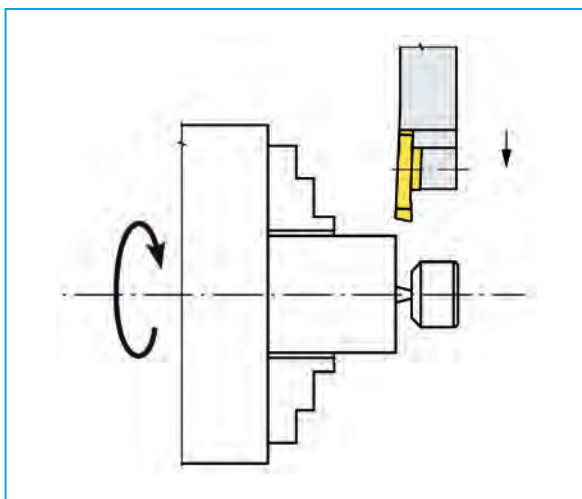

MULTICUT 4

Only 1 insert pocket for many
different applications.

- Parting off and grooving
- Threading
- Precision grooving
- Full radius grooving
- Special profiles

MULTICUT 4 - V chip breaker, inserts with 4 edges grooving and parting off

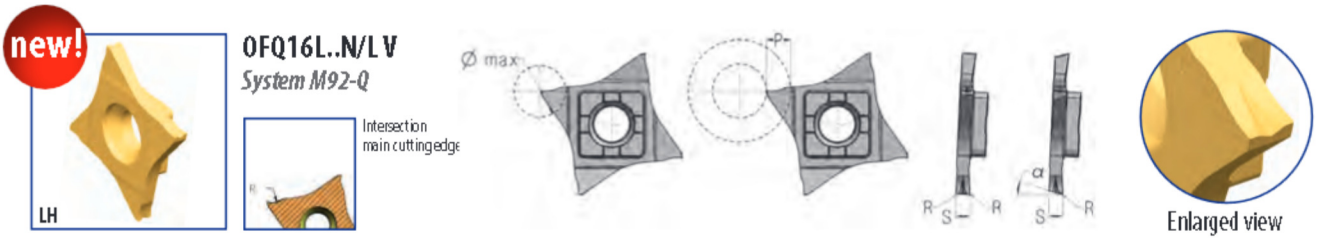

W G400 Ref.	FM NANOSPEED ID-Nr.	FM TILOX ID-Nr.	⌀	P	R	$s \pm 0,05$	α°	Ømax.
OFQ16L 150 000 N 00V	33125	33123	N	6,5	0,00	1,50	0	13,0
OFQ16L 200 010 N 00V	33127	33126	N	6,5	0,10	2,00	0	13,0
OFQ16L 250 010 N 00V	33130	33128	N	6,5	0,10	2,50	0	13,0
OFQ16L 300 010 N 00V	33151	33150	N	6,5	0,10	3,00	0	13,0
OFQ16L 150 000 L 06V	33133	33132	L	6,5	0,00	1,50	6	13,0
OFQ16L 200 010 L 06V	33135	33134	L	6,5	0,10	2,00	6	13,0
OFQ16L 200 010 L 15V	33137	33136	L	6,5	0,10	2,00	15	13,0

Segmented and ground micrograin insert. Positive top-rake with **chipforming** groove.

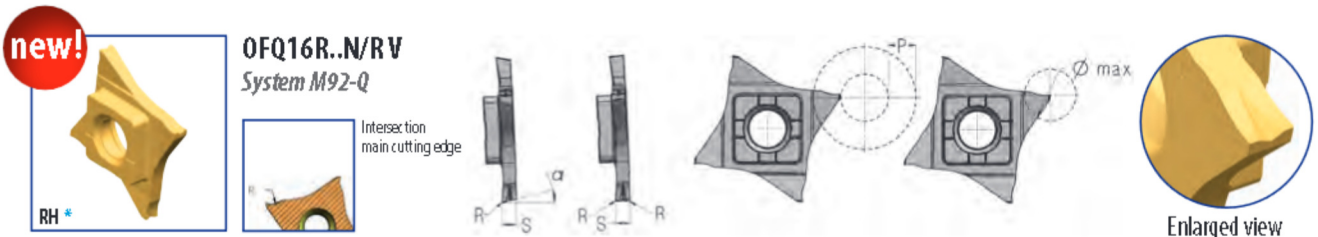

W G400 Ref.	FM NANOSPEED ID-Nr.	FM TILOX ID-Nr.	⌀	P	R	$s \pm 0,05$	α°	Ømax.
OFQ16R 150 000 N 00V	33139	33138	N	6,5	0,00	1,50	0	13,0
OFQ16R 200 010 N 00V	33141	33140	N	6,5	0,10	2,00	0	13,0
OFQ16R 250 010 N 00V	33143	33142	N	6,5	0,10	2,50	0	13,0
OFQ16R 300 010 N 00V	33153	33152	N	6,5	0,10	3,00	0	13,0
OFQ16R 150 000 R 06V	33145	33144	R	6,5	0,00	1,50	6	13,0
OFQ16R 200 010 R 06V	33147	33146	R	6,5	0,10	2,00	6	13,0
OFQ16R 200 010 R 15V	33149	33148	R	6,5	0,10	2,00	15	13,0

Segmented and ground micrograin insert. Positive top-rake with **chipforming** groove.

MULTICUT 4 - Perfect chip forming with V-Chip breakers

OFQ16R 200 010 N00 V FM NANOSPEED

1.4571
 $V_c = 80 \text{ m/min}$
 $F = 0,08 \text{ mm/U.}$

1.4571
 $V_c = 80 \text{ m/min}$
 $F = 0,12 \text{ mm/U.}$

1.7227
 $V_c = 150 \text{ m/min}$
 $F = 0,08 \text{ mm/U.}$

1.7227
 $V_c = 150 \text{ m/min}$
 $F = 0,12 \text{ mm/U.}$

1.7131
 $V_c = 150 \text{ m/min}$
 $F = 0,08 \text{ mm/U.}$

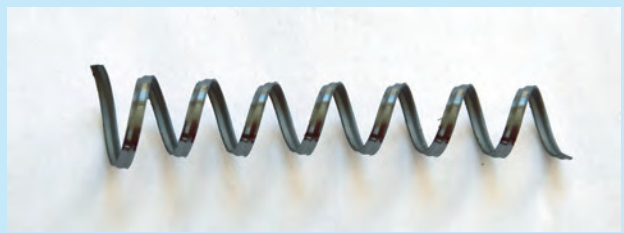
1.7131
 $V_c = 150 \text{ m/min}$
 $F = 0,12 \text{ mm/U.}$

MULTICUT 4 - Precision grooving inserts according to DIN 471



OFQ16L...N
System M92-Q

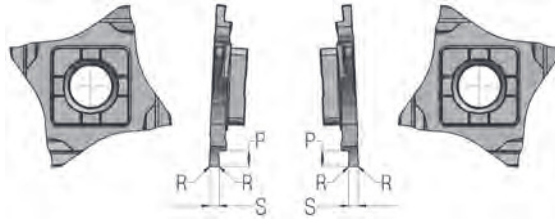

OFQ16R...N
System M92-Q



WG400 Ref.	FM NANOSPEED ID-Nr.	FM TILOX ID-Nr.	(C)	P	R		s ^{-0,05}
OFQ16L 050 000 N	31152	31153	L	1,0	0,00	0,50	0,57
OFQ16L 060 000 N	31154	31155	L	1,0	0,00	0,60	0,67
OFQ16L 070 000 N	31156	31157	L	1,5	0,00	0,70	0,77
OFQ16L 080 000 N	31158	31159	L	1,5	0,00	0,80	0,87
OFQ16L 090 000 N	31160	31161	L	1,5	0,00	0,90	0,97
OFQ16L 100 000 N	38725	38727	L	1,5	0,00	1,00	1,07
OFQ16L 110 010 N	31162	31163	L	1,5	0,10	1,10	1,24
OFQ16L 130 010 N	31164	31165	L	1,5	0,10	1,30	1,44
OFQ16L 160 010 N	31172	31173	L	2,0	0,10	1,60	1,74
OFQ16L 185 010 N	31174	31175	L	2,0	0,10	1,85	1,99
OFQ16L 215 010 N	31176	31177	L	2,5	0,10	2,15	2,29
OFQ16L 265 010 N	31178	31179	L	2,5	0,10	2,65	2,79
OFQ16L 315 010 N	31180	31181	L	2,5	0,10	3,15	3,29
OFQ16R 050 000 N	31127	31128	R	1,0	0,00	0,50	0,57
OFQ16R 060 000 N	31129	31130	R	1,0	0,00	0,60	0,67
OFQ16R 070 000 N	31131	31132	R	1,5	0,00	0,70	0,77
OFQ16R 080 000 N	31133	31134	R	1,5	0,00	0,80	0,87
OFQ16R 090 000 N	31136	31137	R	1,5	0,00	0,90	0,97
OFQ16R 100 000 N	38726	38728	R	1,5	0,00	1,00	1,07
OFQ16R 110 010 N	31138	31139	R	1,5	0,10	1,10	1,24
OFQ16R 130 010 N	31140	31141	R	1,5	0,10	1,30	1,44
OFQ16R 160 010 N	31142	31143	R	2,0	0,10	1,60	1,74
OFQ16R 185 010 N	31144	31145	R	2,0	0,10	1,85	1,99
OFQ16R 215 010 N	31146	31147	R	2,5	0,10	2,15	2,29
OFQ16R 265 010 N	31148	31149	R	2,5	0,10	2,65	2,79
OFQ16R 315 010 N	31150	31151	R	2,5	0,10	3,15	3,29

Comment:

Segmented and ground micrograin insert.
Horizontal cutting edge and positive top rake.



Enlarged LH edge

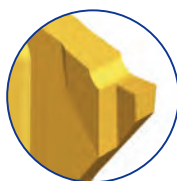

Enlarged RH edge

Fitting tool holders and blades



p. 35



p. 36



p. 36

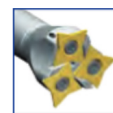

p. 43 - 44



p. 159

MULTICUT 4 - Full radius insert for grooving and copying



OFQ16L..R..N
System M92-Q

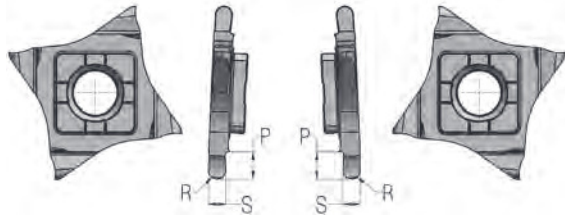

OFQ16R..R..N
System M92-Q



WG400 Ref.	FM NANOSPEED ID-Nr.	FM TILOX ID-Nr.	(C)	P	R	s +0,05
OFQ16L 100 R050 N	31202	31203	L	1,0	0,50	1,00
OFQ16L 150 R075 N	31204	31205	L	1,5	0,75	1,50
OFQ16L 200 R100 N	31206	31207	L	2,0	1,00	2,00
OFQ16L 250 R125 N	31208	31209	L	2,5	1,25	2,50
OFQ16L 300 R150 N	31210	31211	L	3,0	1,50	3,00
OFQ16R 100 R050 N	31187	31188	R	1,0	0,50	1,00
OFQ16R 150 R075 N	31189	31190	R	1,5	0,75	1,50
OFQ16R 200 R100 N	31191	31192	R	2,0	1,00	2,00
OFQ16R 250 R125 N	31193	31194	R	2,5	1,25	2,50
OFQ16R 300 R150 N	31195	31196	R	3,0	1,50	3,00

Comment:

Segmented and ground micrograin insert.
Horizontal cutting edge and positive top rake.

Fitting tool holders and blades

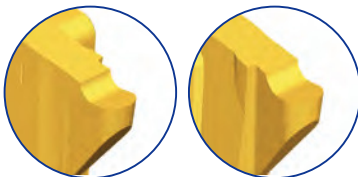

Enlarged LH edge

Enlarged RH edge

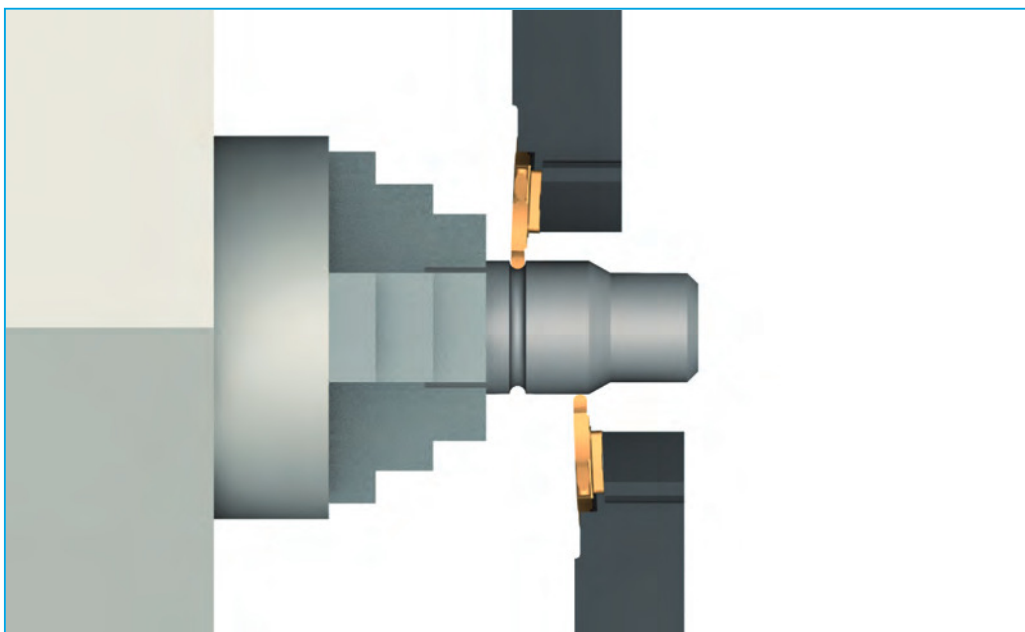

Full radius groove and copying with MC4 full radius inserts.

Technical section page 205 onwards

MULTICUT 4 - Precision threading inserts external for ISO- and Whitworth full profile



OFQ16L...EL
System M92-Q

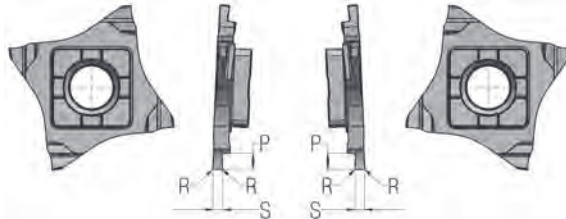

OFQ16R...ER
System M92-Q



WG400 Ref.	FM NANOSPEED ID-Nr.	FM TILOX ID-Nr.	(C)		A	P	S	α°
OFQ16L 200 050 EL ISO	31418	31419	L	0,50	0,5	6,5	2,0	60
OFQ16L 200 070 EL ISO	31420	31421	L	0,70	0,5	6,5	2,0	60
OFQ16L 200 075 EL ISO	31422	31423	L	0,75	0,5	6,5	2,0	60
OFQ16L 200 080 EL ISO	31424	31425	L	0,80	0,7	6,5	2,0	60
OFQ16L 200 100 EL ISO	31426	31427	L	1,00	0,7	6,5	2,0	60
OFQ16L 200 125 EL ISO	31428	31429	L	1,25	0,7	6,5	2,0	60
OFQ16L 200 28W EL	31430	31431	L	28 G/Zoll	1,0	6,5	2,0	55
OFQ16L 200 19W EL	31432	31433	L	19 G/Zoll	1,0	6,5	2,0	55
OFQ16L 350 14W EL	31434	31435	L	14 G/Zoll	1,3	6,5	3,5	55
OFQ16L 350 11W EL	31436	31437	L	11 G/Zoll	1,5	6,5	3,5	55
OFQ16L 350 150 EL ISO	31438	31439	L	1,50	0,8	6,5	3,5	60
OFQ16L 350 175 EL ISO	31440	31441	L	1,75	0,9	6,5	3,5	60
OFQ16L 350 200 EL ISO	31442	31443	L	2,00	1,0	6,5	3,5	60
OFQ16L 350 250 EL ISO	37451	34994	L	2,50	1,3	6,5	3,5	60
OFQ16L 350 300 EL ISO	37452	34995	L	3,00	1,8	6,5	3,5	60
OFQ16R 200 050 ER ISO	31294	31297	R	0,50	0,5	6,5	2,0	60
OFQ16R 200 070 ER ISO	31298	31299	R	0,70	0,5	6,5	2,0	60
OFQ16R 200 075 ER ISO	31393	31394	R	0,75	0,5	6,5	2,0	60
OFQ16R 200 080 ER ISO	31395	31396	R	0,80	0,7	6,5	2,0	60
OFQ16R 200 100 ER ISO	31397	31400	R	1,00	0,7	6,5	2,0	60
OFQ16R 200 125 ER ISO	31401	31402	R	1,25	0,7	6,5	2,0	60
OFQ16R 200 28W ER	31403	31404	R	28 G/Zoll	1,0	6,5	2,0	55
OFQ16R 200 19W ER	31405	31406	R	19 G/Zoll	1,0	6,5	2,0	55
OFQ16R 350 14W ER	31407	31408	R	14 G/Zoll	1,3	6,5	3,5	55
OFQ16R 350 11W ER	31409	31410	R	11 G/Zoll	1,5	6,5	3,5	55
OFQ16R 350 150 ER ISO	31411	31412	R	1,50	0,8	6,5	3,5	60
OFQ16R 350 175 ER ISO	31413	31414	R	1,75	0,9	6,5	3,5	60
OFQ16R 350 200 ER ISO	31415	31417	R	2,00	1,0	6,5	3,5	60
OFQ16R 350 250 ER ISO	37450	34992	R	2,50	1,3	6,5	3,5	60
OFQ16R 350 300 ER ISO	34130	34993	R	3,00	1,8	6,5	3,5	60

LH inserts: Delivery time and price on request, minimum purchase 3 pieces.

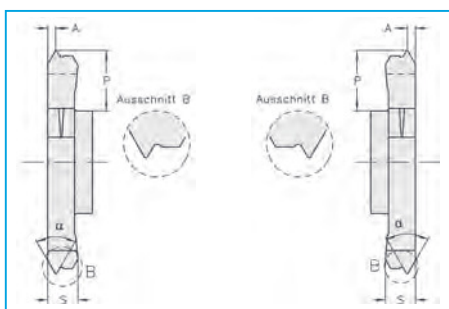

Precision ground threading inserts for external threads:

The vertical position of the insert, its positive top rake, large chip chambers, large front clearance and coated micrograin carbide together create perfect conditions for difficult threading operations.

Fitting tool holders and blades



MULTICUT 4 - Part profile threading inserts for ISO- and Whitworth full profile



OFQ16L...EIR
System M92-Q

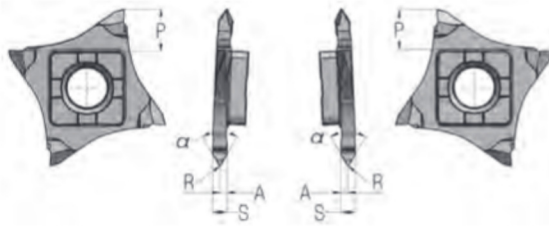

OFQ16R...EIR
System M92-Q



WG400 Ref.	FM NANOSPEED ID-Nr.	FM TILOX ID-Nr.	⌀		A	P	R	S	α°
OFQ16L 200 EIR55 28 W	43128	43129	L	28-20 G/Zoll	0,9	6,5	0,1	2,0	55
OFQ16L 200 EIR60 050	43130	43131	L	0,5-1,00	0,9	6,5	0,1	2,0	60
OFQ16L 250 EIR55 19 W	43132	43133	L	19-14 G/Zoll	1,2	6,5	0,2	2,5	55
OFQ16L 250 EIR60 125	43134	43135	L	1,25-1,75	1,2	6,5	0,2	2,5	60
OFQ16L 350 EIR55 12 W	43136	43137	L	12-10 G/Zoll	1,8	6,5	0,3	3,5	55
OFQ16L 350 EIR60 200	43138	43139	L	2,00-3,00	1,8	6,5	0,3	3,5	60
OFQ16R 200 EIR55 28 W	43140	43141	R	28-20 G/Zoll	0,9	6,5	0,1	2,0	55
OFQ16R 200 EIR60 050	43142	43143	R	0,5-1,00	0,9	6,5	0,1	2,0	60
OFQ16R 250 EIR55 19 W	43144	43145	R	19-14 G/Zoll	1,2	6,5	0,2	2,5	55
OFQ16R 250 EIR60 125	43146	43147	R	1,25-1,75	1,2	6,5	0,2	2,5	60
OFQ16R 350 EIR55 12 W	43148	43149	R	12-10 G/Zoll	1,8	6,5	0,3	3,5	55
OFQ16R 350 EIR60 200	43150	43151	R	2,00-3,00	1,8	6,5	0,3	3,5	60

LH inserts: Delivery time and price on request, minimum purchase 3 pieces.

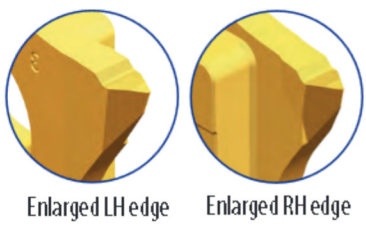

Fitting tool holders and blades



Optimal clamping and releasing - Special screwdriver for MULTICUT 4 holders and blades
(included in orderextensive)

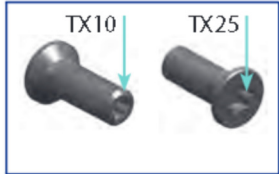
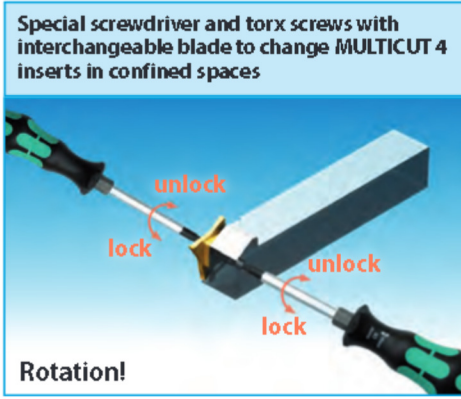

ET-Nr.	WG355 Ref.	ID-Nr.	Item	Recommended torque max. [Nm]
33	TXMSx14 1025	44641	Torxschraube L=14	4,5
34	TXMSx10 1025	44817	Torxschraube L=10	4,5

Ordering data

WG355 Ref.	ID-Nr.	Item
TX25 10 1	45131	Setcontents: 39 + 40 + 33
TX25 10 2	45132	Setcontents: 39 + 40 + 34

Technical section page 205 onwards

Detailed description on page 229

MULTICUT 4 - Tool Designation Code

M92 Q FXCB L 2020 M 16

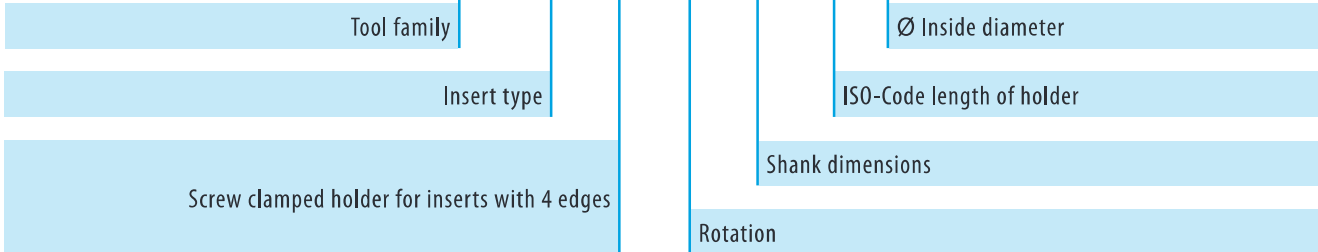

MULTICUT 4 - holders for cutting, threading and precision grooving inserts



M92 Q...L
System M92-Q

LH holder
for LH insert

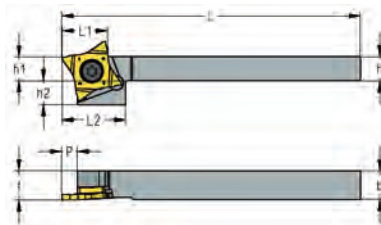

M92 Q...R
System M92-Q

RH holder for
RH inserts



WG402 Ref.	ID-Nr.	↺	h	h1	h2	b	f	P	L	L1	L2	
M92 Q FXCBL 1012 K16	30306	L	10	10	10	12	12,3	6,5	125	19,5	27	34+39+40
M92 Q FXCBL 1212 K16	30312	L	12	12	8	12	12,3	6,5	125	19,5	27	34+39+40
M92 Q FXCBL 1616 K16	30316	L	16	16	4	16	16,3	6,5	125	19,5	19,5	33+39+40
M92 Q FXCBL 2020 K16	29120	L	20	20	-	20	20,3	6,5	125	19,5	-	33+39+40
M92 Q FXCBL 2525 M16	30320	L	25	25	-	25	25,3	6,5	150	19,5	-	33+39+40
M92 Q FXCBR 1012 K16	30324	R	10	10	10	12	12,3	6,5	125	19,5	27	34+39+40
M92 Q FXCBR 1212 K16	30328	R	12	12	8	12	12,3	6,5	125	19,5	27	34+39+40
M92 Q FXCBR 1616 K16	30332	R	16	16	4	16	16,3	6,5	125	19,5	19,5	33+39+40
M92 Q FXCBR 2020 K16	30302	R	20	20	-	20	20,3	6,5	125	19,5	-	33+39+40
M92 Q FXCBR 2525 M16	30336	R	25	25	-	25	25,3	6,5	150	19,5	-	33+39+40

Remark:

Only RH inserts will fit into RH tool holders and blades.
 Only LH inserts will fit into LH tool holders and blades.

Fitting inserts

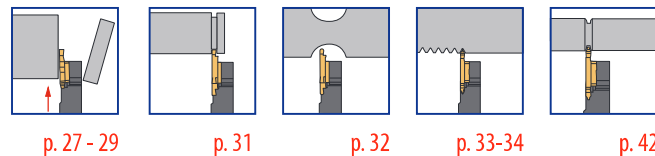

How to write an order:			recommended
1 St.	M92 Q FXCBR 1012 K16	or:	1 St. ID-Nr. 30324
5 St.	OFQ 16R 050 000N FM TILOX	or:	5 St. ID-Nr. 31128



MULTICUT 4 - 90° holders for many different turning applications

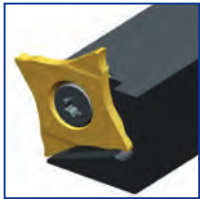

M92 Q 90 FXCBL
System M92-Q

LH holder for RH inserts

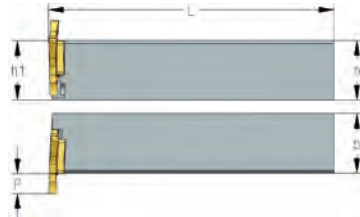

M92 Q 90 FXCBR
System M92-Q

RH holder for LH inserts

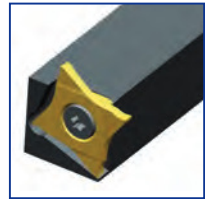

WG402 Ref.	ID-Nr.	(C)	h	h1	b	P	L	
M92 Q 90 FXCBL 2020 K16	43343	L	20	20	20	6,5	125	33+39+40
M92 Q 90 FXCBR 2020 K16	43342	R	20	20	20	6,5	125	33+39+40

Attention:
RH inserts fit LH holders.
LH inserts fit RH holders.

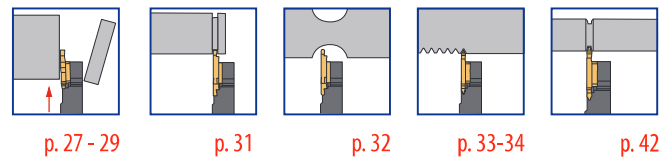

Fitting inserts



p.227-228,238

MULTICUT 4 - blades for cutting, threading and precision grooving inserts



M92 Q...X..L
System M92-Q

LH blade for LH inserts

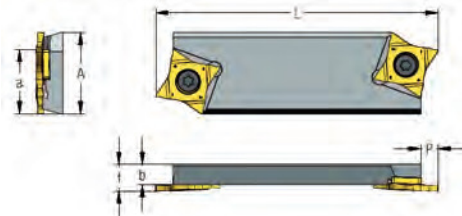

M92 Q...X..R
System M92-Q

RH blade for RH inserts

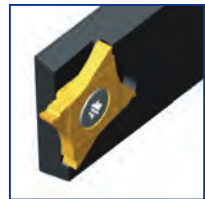

WG401 Ref.	ID-Nr.	(C)	A	a	b	f	P	L	
M92 Q FXCBL 2608 X16L	30349	L	26	21,4	8	10,5	6,5	110	34+39+40
M92 Q FXCBL 3208 X16L	29116	L	32	25,0	8	10,5	6,5	110	34+39+40
M92 Q FXCBR 2608 X16R	30353	R	26	21,4	8	10,5	6,5	110	34+39+40
M92 Q FXCBR 3208 X16R	30345	R	32	25,0	8	10,5	6,5	110	34+39+40

Remark:

Each blade has got **2 insert pockets**.
Only RH inserts will fit into RH tool holders and blades.
Only LH inserts will fit into LH tool holders and blades.

LH = Left Hand = for clockwise (CW) rotation
RH = Right Hand = for counter clockwise (CCW) rotation

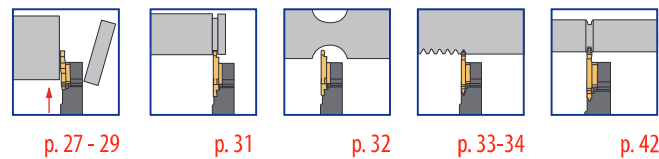

Fitting inserts

How to write an order:			recommended
1 St.	M92 Q FXCBR 2608 X16R	or:	1 St. ID-Nr. 30353
5 St.	OFQ 16R 050 000N FM TILOX	or:	5 St. ID-Nr. 31128



p.227-229,238